



INSTALLATION INSTRUCTIONS

# MOBIUS INDOOR/OUTDOOR

MULTI-POLARIZED CONTINUOUS WIDE BAND ANTENNA

**PACKAGE CONTENTS:**

- Mobius Antenna
- Support Washer
- Lock Washer
- Nut

MP Antenna, LTD.  
7887 Bliss Parkway  
North Ridgeville, Ohio 44039

877 678 3243 *phone*  
877 678 3245 *fax*  
sales@mpantenna.com  
www.mpantenna.com

## Adhesive Mount Instructions

1. Drill hole through mounting surface large enough to fit mounting stud.
2. Install support washer, lock washer and nut then tighten.
3. Attach cable to N-Female Connector.

\* Moisture within cable and connectors can significantly degrade performance. MP Antenna recommends all connections be sealed water tight to ensure optimal performance. Connections must not be made in a damp or wet environment.

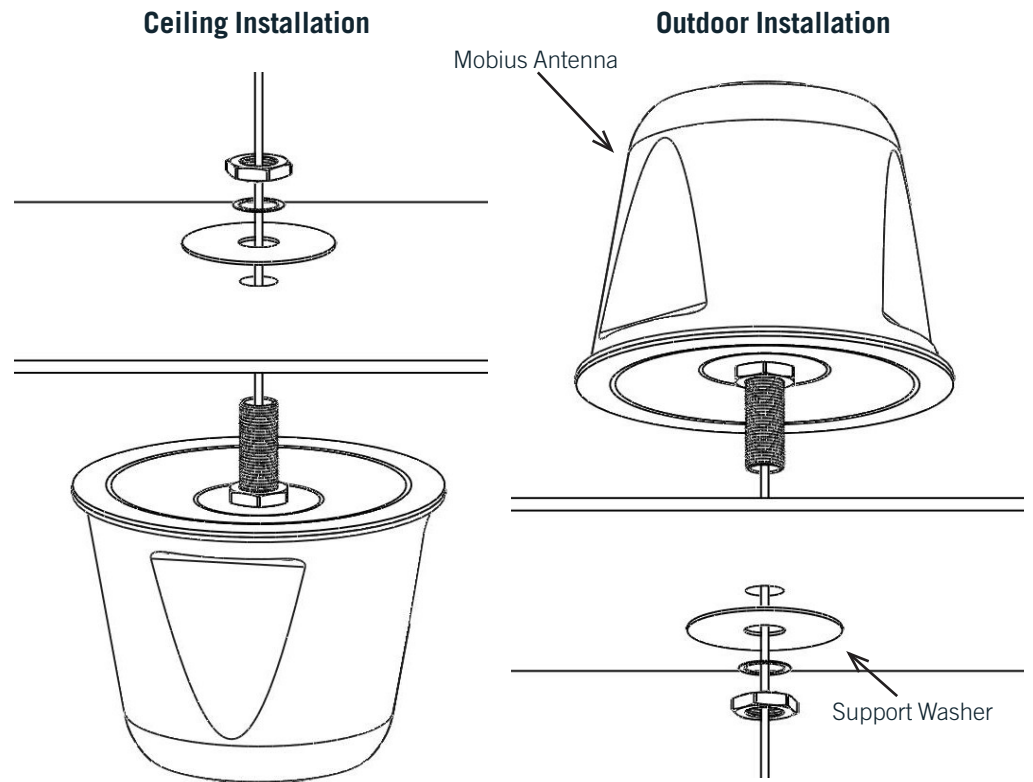

rethink the antenna™

MP Antenna reserves the right to change product information and specifications without notice. Responsibility for the use and application of MP Antenna products rests with the end user since MP Antenna cannot be aware of all potential uses. MP Antenna makes no warranties as to the fitness, merchantability, or suitability of any MP Antenna products for any specific or general uses. MP Antenna shall not be liable for incidental or consequential damages of any kind.\* MP Antenna products and technology are protected under United States Patent No. 6,496,152 and other patents applied for. Please contact MP Antenna for information about using or licensing MP Antenna products or technology.



INSTALLATION INSTRUCTIONS

# MOBIUS MOBILE

MULTI-POLARIZED CONTINUOUS WIDE BAND ANTENNA

**PACKAGE CONTENTS:**

- Mobius Antenna
- Gasket
- Lock Washer
- Nut

MP Antenna, LTD.  
7887 Bliss Parkway  
North Ridgeville, Ohio 44039

877 678 3243 *phone*  
877 678 3245 *fax*  
sales@mpantenna.com  
www.mpantenna.com

## Adhesive Mount Instructions

1. Drill hole through mounting surface large enough to fit mounting stud.
2. Install lock washer and nut then tighten.
3. Attach cable to N-Female Connector.

\* Moisture within cable and connectors can significantly degrade performance. MP Antenna recommends all connections be sealed water tight to ensure optimal performance. Connections must not be made in a damp or wet environment.

### Mobile Installation

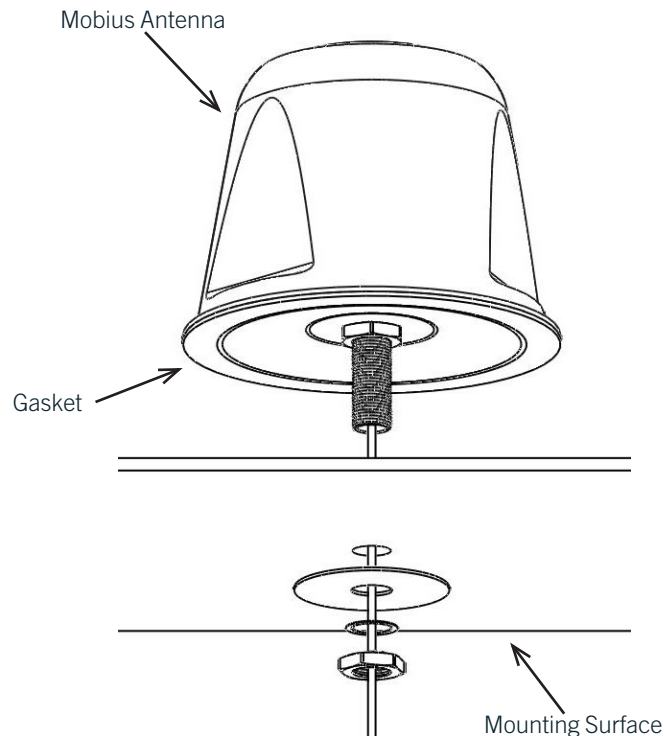

rethink the antenna™

MP Antenna reserves the right to change product information and specifications without notice. Responsibility for the use and application of MP Antenna products rests with the end user since MP Antenna cannot be aware of all potential uses. MP Antenna makes no warranties as to the fitness, merchantability, or suitability of any MP Antenna products for any specific or general uses. MP Antenna shall not be liable for incidental or consequential damages of any kind.\* MP Antenna products and technology are protected under United States Patent No. 6,496,152 and other patents applied for. Please contact MP Antenna for information about using or licensing MP Antenna products or technology.